



# Teaching Pendant SEL-T, TD, TG First Step Guide Fifth Edition

Thank you for purchasing our product.  
Make sure to read the Safety Guide and detailed Operation Manual (CD/DVD) included with the product in addition to this First Step Guide to ensure correct use.  
This Operation Manual is original.

**Warning:** Operation of this equipment requires detailed installation and operation instructions which are provided on the CD/DVD Manual included in the box this device was packaged in. It should be retained with this device at all times.  
A copy of the CD/DVD Manual can be requested by contacting your nearest IAI Sales Office listed at the back cover of the Instruction Manual or on the First Step Guide.

- Using or copying all or part of this Operation Manual without permission is prohibited.
- The company names, names of products and trademarks of each company shown in the sentences are registered trademarks.

## Product Check

This product is comprised of the following parts if it is of standard configuration.  
If you find any fault in the contained model or any missing parts, contact us or our distributor.

### 1. Parts (The option is excluded.)

No.	Part Name	Model	Reference
1	Main Body	Refer to "How to read the model plate", "How to read the model"	
<b>Accessories</b>			
2	First Step Guide	ME0280	
3	Instruction Manual (CD/DVD)		
4	Safety Guide	M0194	

### 2. Instruction Manuals related to this product, which are contained in the Instruction Manuals (CD/DVD).

No.	Name	Manual No.
1	Teaching Pendant SEL-T/TD/TG Instruction Manual	ME0183
2	XSEL-J/K Controller Instruction Manual	ME0116
3	XSEL-JX/KX Controller Instruction Manual	ME0119
4	XSEL-P/Q/PCT/QCT Controller Instruction Manual	ME0148
5	XSEL-PX/QX Controller Instruction Manual	ME0154
6	XSEL-R/S/RX/SX/RXD/SXD Controller Instruction Manual	ME0313
7	Table Top Type Robot TT Instruction Manual	ME0149
8	Table Top Type Robot TTA Instruction Manual	ME0320
9	SSEL Controller Instruction Manual	ME0157
10	ASEL Controller Instruction Manual	ME0165
11	PSEL Controller Instruction Manual	ME0172

### 3. How to read the model plate

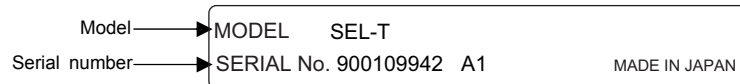

### 4. How to read the model

#### SEL-T-J

<Model>  
For XSEL Controller, and TT  
SEL-T : Standard type  
SEL-TD : Deadman switch equipped type  
SEL-TG-25 : Safety category 4 compliance type

For ASEL, PSEL and SSEL Controller  
SEL-T-J : Standard type, with connector converter cable  
SEL-T-JS : Standard type, with connector converter cable  
SEL-TD-J : Deadman switch equipped type with connector converter cable  
SEL-TD-JS : Deadman switch equipped type with connector converter cable  
SEL-TG-26H : Safety category 4 compliance type

## Support Models

List of Support Models	
Model No.	Support Started Version
XSEL-K	V1.00
XSEL-KX	V1.00
XSEL-P/Q	V1.00
XSEL-PCT/QCT	V1.00
XSEL-PX/QX	V1.00
TT	V1.00
SSEL	V1.00
ASEL	V1.00
PSEL	V1.00
XSEL-R/S	V1.12
XSEL-RX/SX	V1.12
XSEL-RXD/SXD	V1.12
TTA	V1.16

## Basic Specifications

Item	Specification
Compliance with UL and CE Standards	Compliant
Surrounding Air Temperature & Humidity	Temperature : 0 to 40°C Humidity : 10 to 90% (non-condensing)
Protection Code	IP54 (Excluding cable connectors)
Surrounding Environment	No corrosive gas
Weight	Approx. 0.4kg (Excluding cables)
Cable Length	5m

## External Dimensions

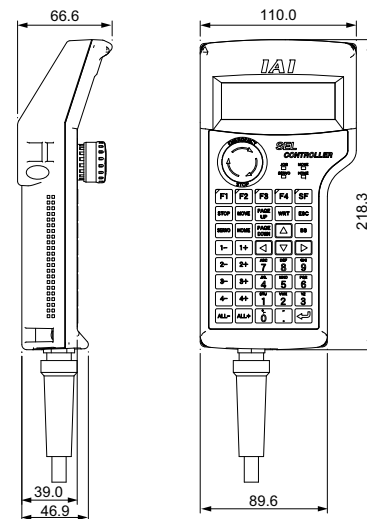

## Connection Diagram

[SEL-T]

Connect to the teaching connector. Shown below is a connection to XSEL-P type for an example.

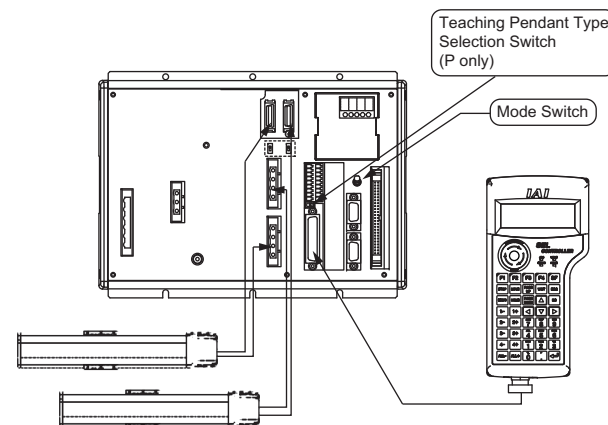

(Note) Set the teaching pendant type selection switch of the XSEL-P type to the left.

### [Connection of the SEL-TG and IA-LB-TG]

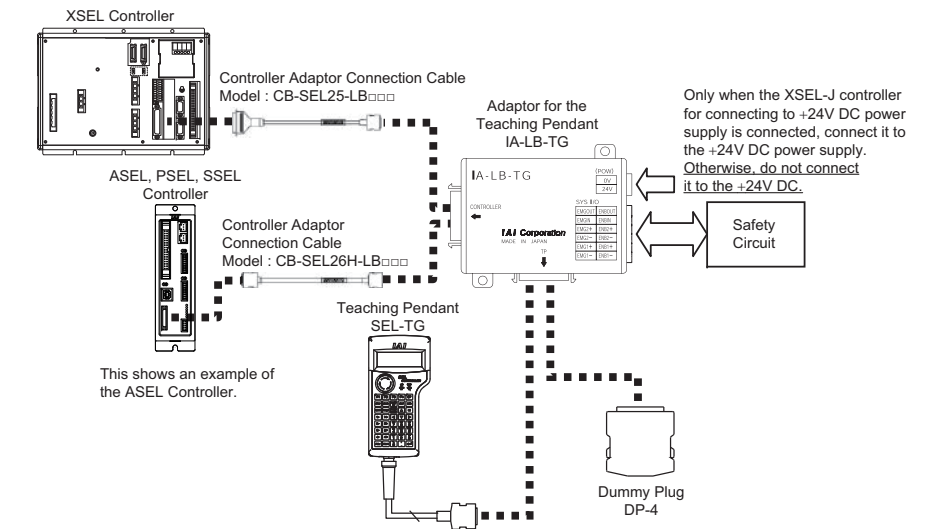

Note : When the teaching pendant SEL-TG is not to be connected, make sure to insert the dummy plug DP-4 into the adaptor for the teaching pendant.

### [Connection of the SEL-TD and IA-LB-TGS]

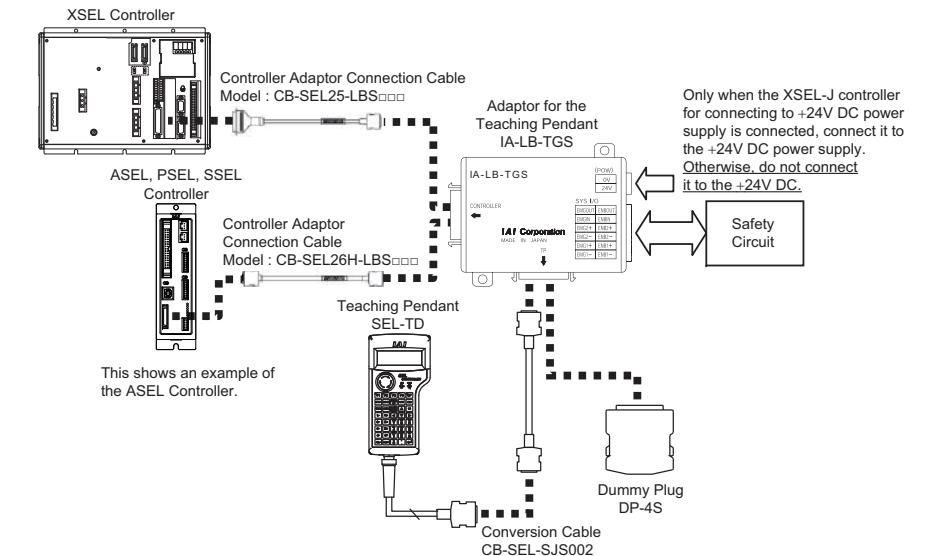

Note : When the teaching pendant SEL-TD is not to be connected, make sure to insert the dummy plug DP-4S into the adaptor for the teaching pendant.

### [Connection of the SEL-TG and IA-LB-TGS]

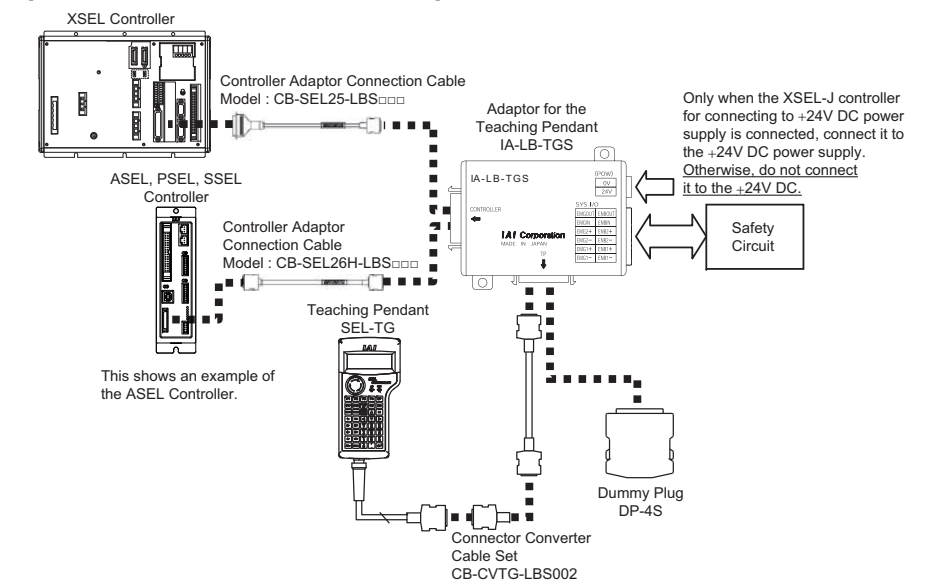

Note : When the teaching pendant SEL-TG is not to be connected, make sure to insert the dummy plug DP-4S into the adaptor for the teaching pendant.

## Operation Panel

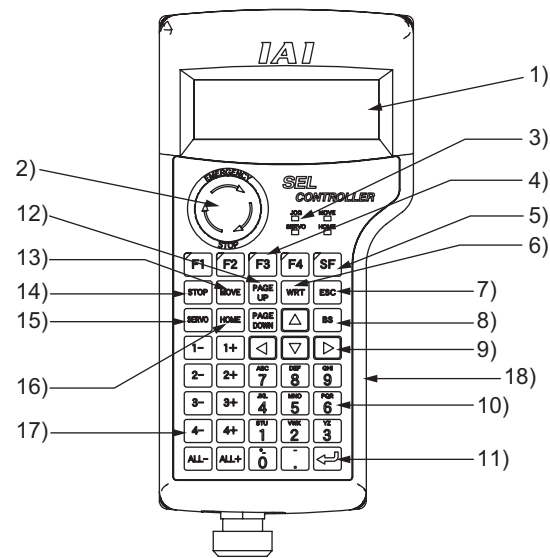

- 1) LCD Screen
- 2) EMERGENCY STOP (Emergency Stop Push Button Switch)  
Executes emergency stop.
- 3) LED
  - JOG  
When this LED is lit, jog operation is possible with **1-**, **2-**, **3-**, **4-**, **ALL-**, **1+**, **2+**, **3+**, **4+** or **ALL+**.
  - MOVE  
When this LED is lit, position movement or continuous movement operation is possible with **1-**, **2-**, **3-**, **4-**, **ALL-**, **1+**, **2+**, **3+**, **4+** or **ALL+**.
  - SERVO  
When this LED is lit, servo ON/OFF operation is possible with **1-**, **2-**, **3-**, **4-**, **ALL-**, **1+**, **2+**, **3+**, **4+** or **ALL+**.
  - HOME  
When this LED is lit, homing operation is possible with **1-**, **2-**, **3-**, **4-**, **ALL-**, **1+**, **2+**, **3+**, **4+** or **ALL+**.
- 4) **F1** **F2** **F3** **F4** keys (Function keys)  
Correspond to each item in the LCD Screen (function key section).  
The LED is lit when the relevant key is operable.

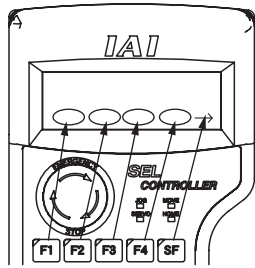

- 5) **SF** key (Shift key)  
If there are more than 5 selectable functions ("→" will be displayed at right side of the function key area), it will change the display items in the function key area. When the key is operable, its LED is lit.
- 6) **WRT** key (Write key)  
Transmits edit data to the controller. (Data will be saved in the memory of the controller.)  
Only the data shows on the LCD Screen will be transmitted. (Plural Position No., Program Step No., etc., can't be transmitted all together at the same time.)
- 7) **ESC** key (Escape key)  
Returns to the previous status from the current status.  
If you press this key during data input, the data will be cancelled.
- 8) **BS** key (Backspace key)  
If you press this key during data input, clear one letter before.  
At other time, clear the data where the cursor is placed.
- 9) **←** **↑** **↓** **→** (Cursor key)  
Moves the cursor.
- 10) Numeral keys  
You can input numeric, alphabet, and sign.  
When the cursor is at any item requiring the input of characters other than "0" to "9" (such as hexadecimal and character strings), the input mode selection is displayed in the function key area. (Alph: alphabet symbol input, Num: numerical value input)

- 11) **↵** key (Return key)  
Confirms the input data and moves the cursor position forward.
- 12) **↑** **↓** key (PAGE UP · PAGE DOWN key)  
Increment or decrement edit and display item No. (Position No., Program No., Step No., etc.)
- 13) **MOVE** key  
Enables actuator movement or continuous operation. The LED of MOVE is lit.  
(It is valid in the Teac (teach) mode area.)  
When you press a jog key such as **1+** and **1-** after enabling movement or continuous operation, movement action starts. However, it is required to switch servo ON when the servo is OFF.  
Jog operation is made possible after the action has been completed or stopped. The LED of JOG is lit up.
- 14) **STOP** key  
Stops actuator movement or continuous movement. (It is valid in the Teac (teach) mode area with the servo ON.)
- 15) **SERVO** key  
Enables axis servo ON/OFF switching operation. The LED of SERVO is lit up.  
(It is valid in the Teac (teach) mode area.)  
When you press a + jog key such as **1+** after enabling servo ON/OFF switching operation, the servo is turned ON. When you press a - jog key such as **1-**, the servo is turned OFF.  
Jog operation is made possible after the servo has been turned ON/OFF. The LED of JOG is lit. However, when the servo is OFF, the actuator cannot be moved by jog or inching operation unless the servo is turned ON.
- 16) **HOME** key  
Enables homing operation. The LED of HOME is lit. (It is valid in the Teac (teach) mode area.)  
When you press a jog key such as **1+** and **1-** after enabling homing operation, homing starts. However, it is required to turn the servo ON when the servo is OFF.  
Jog operation is made possible after homing has been completed. The LED of JOG is lit.
- 17) **1-** **1+** **2-** **2+** **3-** **3+** **4-** **4+** **ALL-** and **ALL+** (Jog keys)
 

<b>1-</b>	Negative direction jog movement for the 1st axis and 5th axis
<b>1+</b>	Positive direction jog movement for the 1st axis and 5th axis
<b>2-</b>	Negative direction jog movement for the 2nd axis and 6th axis
<b>2+</b>	Positive direction jog movement for the 2nd axis and 6th axis
<b>3-</b>	Negative direction jog movement for the 3rd axis
<b>3+</b>	Positive direction jog movement for the 3rd axis
<b>4-</b>	Negative direction jog movement for the 4th axis
<b>4+</b>	Positive direction jog movement for the 4th axis
<b>ALL-</b>	Negative direction jog movement for all axes
<b>ALL+</b>	Positive direction jog movement for all axes

(It is valid in the Teac (teach) mode area with the servo ON)

- Such jog actions with the JOG button are also valid for any not-homed axes. However, coordinate values in this case have no meaning. Therefore, be extremely careful about interference with the stroke end.
- If jog operation is performed to the axis in action under the operation-button-acceptable condition, the operation of the applicable axis is aborted when the JOG operation button is turned OFF. (The next operation starts, if any.)

- 18) Deadman Switch \*Option  
There are three stages for the dead-man switch. The ON/OFF in each stage are described as follows.

1st Stage	Switch OFF	The condition where finger is released from the switch, or the force of pressing the switch is very weak.
2nd Stage	Switch ON	Condition where the switch is pressed with appropriate force.
3rd Stage	Switch OFF	Condition where the switch is pressed strongly.

The servo-motor can be turned ON under the switch ON condition.  
When the switch is turned OFF, the driving power source is disconnected and the servo-motor is turned OFF.

Even when the switch is turned OFF, the operations in the modes where turning ON the servo-motor is not required are available (such as edit mode)

- Some controllers such as the X-SEL-K controller display the message shown below when the power is turned ON.  
If you press the **ESC** key, the mode selection screen will be displayed and operation will become possible in the mode not requiring servo ON even in the switch OFF condition.

```

M s g [ B E I ]
T P D e a d m a n S w O F F

B a c k N e x t
    
```

- When the switch is OFF, the panel window 7-segment LED of the X-SEL-K or KX controller displays 'dsf'.
- The panel window 7-segment LED of the X-SEL-P/Q, PX/QX controller or TTA displays 'enb'.

- The Deadman switch is valid when the controller's mode switch is on the MANU side.
- The driver power cannot be cut off regardless of the switch condition when the controller's mode switch is on the AUTO side.

## Program Table Input Window

Create a program in the program table. Refer to SEL language programming manual for the details how to create a program.

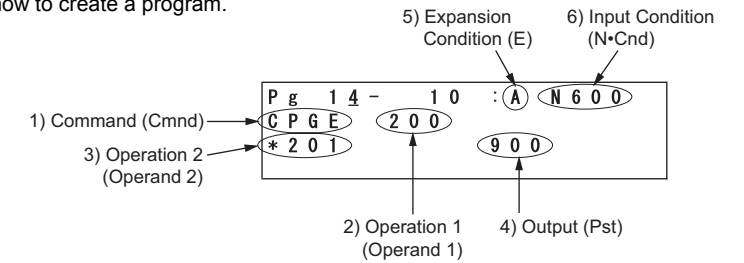

- 1) Command (Cmnd) : It is to input commands and declarations.
- 2) Operation 1 (Operand 1) : It is to input details of Operation 1 related to commands and declarations. For PATH Operation for instance, it is to input the start Position No..
- 3) Operation 2 (Operand 2) : It is to input details of Operation 1 related to commands and declarations. For PATH Operation for instance, it is to input the completion Position No..
- 4) Output (Pst) : It is to input the output port and input port to output the operation completion result after the command is executed.
- 5) Expansion Condition (E) : It is used to join multiple input terms with "AND" or "OR".
- 6) Input Condition (N·Cnd) : If a negative condition is desired for the input term, put N. If the command is to be executed with the conditions of I/O or the flag, put the I/O or flag.

## Position Table Input Window

It is required to set the position (coordinate values), velocity, acceleration and deceleration to the position table.  
The items to set differ depending on the model. Refer to the Instruction Manual of the used controller for the details.

Position Table : Example for Connecting 2 Actuator Axes

Position No.	Axis1	Axis2	Vel	Acc	Dcl
1	0.000	200.000			
2	0.000	400.000	400	0.30	0.30
3					
4					
5	0.000	300.000	200	0.10	0.10
6					



[Window to Input Positioning Position]

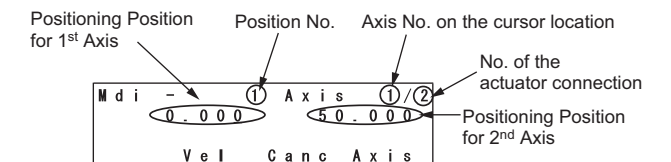

[Window to Input Velocity, Acceleration and Deceleration]

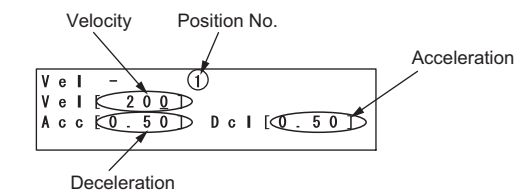

## Operation

After the power is supplied to the controller, a window shown below will be displayed. An operation can be performed on the operation panel. [Refer to the operation panel]

```
SEL Teaching
TP V1.00 07/02/17
TPc V1.00
Connecting...
```

```
Mode Selection
Edit Play Moni Ctl
```

Select a menu and execute.

- Edit (F1 key) : To perform teaching operation to edit program table, position table, etc.
- Play (F2 key) : To drive program.
- Moni (F3 key) : To monitor input and output ports, error list, etc.
- Ctl (F4 key) : To control software reset, absolute reset, safety speed valid/invalid, etc.

The operation window is constructed with a few layers and a selected menu shows some related operation windows.  
[Refer to Teaching Pendant SEL-T/TD/TG Instruction Manual for details.]

## How to Operate (Examples)

### Data Input to Position Table

The chart below shows how to set 0mm to Position No.0 on the 1<sup>st</sup> axis and 50mm to the position on the 2<sup>nd</sup> axis when 2 axes are connected for example.

No.	Operation	Screen	Reference
1	Press <b>[F1]</b> key (Edit).	Mode Selection Edit Play Moni Ctl	
2	Press <b>[F1]</b> key (Posi).	Edit Posi Prog Sym Para	
3	Press <b>[F1]</b> key (Mdi).	Edit-Posi Mdi Teac Copy Ctl	
4	Input a number "0" and press the return key. The display shows "0.000", and the axis number changes to "2" and the cursor position moves to the position data for the 2 <sup>nd</sup> axis.	Mdi - 1 Axis 2/2 0.000 x.xxx Vel Canc Axis	"x.xxx" will be displayed when the position data is not registered.
5	Input "50" to the 2 <sup>nd</sup> axis position data and press the return key.	Mdi - 1 Axis 1/2 0.000 50.000 Vel Canc Axis	The cursor position moves each time the return key is pressed. When you made a typing error, put the cursor to the position where you would like to correct and rewrite. It is also available to change the input data back to "x.xxx" with the (Canc) key.
6	Press <b>[WRT]</b> key to transfer the data. The Position No. gets forwarded to "2".	Position No.2 Mdi - 2 Axis 1/2 x.xxx x.xxx Vel Canc Axis	
7	Press <b>[ESC]</b> key to move the cursor back to the Position No..	Mdi - 2 Axis 1-2/2 x.xxx x.xxx Ctl Axis	
8	Press <b>[ESC]</b> key again to return to Edit Mode.	Edit-Posi Mdi Teac Copy Ctl	
9	Press <b>[ESC]</b> key once again to go to the flash ROM writing window.	Edit Posi Prog Sym Para	
10	Press <b>[F1]</b> (Yes) key if you desire to write the data to the flash ROM.	Flash Write ? Yes No	Press <b>[F2]</b> (No) key if you do not desire a writing.
11	'Please wait...' blinks while in the flash ROM writing process.	Flash Writing Flash ROM Please Wait...	* Do not turn off the controller during this process.
12	Return to the edit window by pressing <b>[ESC]</b> key.	Flash Complete!	
13		Edit Posi Prog Sym Para	

### Data Input to Program Table

The chart below shows how to input 'HOME 11' to Program No.0 for example.

No.	Operation	Screen	Reference
1	Press <b>[F1]</b> key (Edit).	Mode Selection Edit Play Moni Ctl	
2	Press <b>[F1]</b> key (Prog).	Edit Posi Prog Sym Para	
3	Press <b>[F1]</b> key (Mdfy).	Edit-Prog Mdfy Copy Ctl	
4	The display switches to the Program No. input mode window. You will be able to see the cursor on the Program No.. Press the return key to move the cursor to the Step No..	Program No. Step No. Pg 0- 1 : No. of steps for the indicated Program No. stored in the controller	If program data is already input, you should either overwrite (the original data will be erased) the data or select another Program No. with no data being written. The Program No. or the Step No. which the cursor is on can be changed with <b>[PAGE UP]</b> and <b>[PAGE DOWN]</b> keys. Also, the Program No. and the Step No. can be changed by an input of numeral keys and pressing the return key.
5	The cursor moves to the Step No.. Press the return key.	Pg 1- 1 : Ins Del Cmnt / 0	
6	Input the command. The command is displayed in the function key line.  How to Search Command 1) Press <b>[SF]</b> key when the cursor is on the command input line to show the commands in the function line in the alphabetical order. Press <b>[.]</b> key to show them in the back order. 2) Alphabets are allocated to each numeral key. (e.g. For "9", G,H and I are allocated.) Press a numeral key when the cursor is on the command input line, and the first command that starts with an alphabet allocated to the pressed numeral key is displayed in the function key line.  Display the command to input on the function line with the methods 1) and 2), and press the corresponding function key  How to Search HOME Command Press the 9 key to show a command start with either of G, H or I. (Some of the commands cannot be displayed only with the numeral keys. For those, combine the numeral key with <b>[SF]</b> key to display.)  Show "HOME" on the function key line, and then press <b>[F4]</b> (HOME) key. (Press <b>[BS]</b> key if desired to turn the command input line to blank.) Press the return key.	Pg 1- 1 : - ABPG ACC ACHZ ADD -  Command starting with "G" Pg 1- 1 : - EXPG EXSR FMIO GACC -  Command starting with "H" Pg 1- 1 : - GYEL HOLD HOME LFEQ -  Command starting with "I" Pg 1- 1 : - HOME GYEL HOLD HOME LFEQ -	
7	The cursor moves to Operation 1. Input "11" and press the return key.	Pg 1- 1 : HOME - Sym *	
8	Press <b>[WRT]</b> key to transfer the data key to the controller. The Step No. goes forward to 2.	Pg 1- 1 : HOME 11 - Sym *	
9	Press <b>[ESC]</b> key.	Step No.2 Pg 1- 2 : - ABPG ACC ACHZ ADD -	

No.	Operation	Screen	Reference
10	Press <b>[ESC]</b> key. (The cursor moves to the Program No..)	Pg 1- 12 : Ins Del Cmnt / 1	
11	Press <b>[ESC]</b> key. The display goes back to the program edit window.	Pg 1- 12 : / 1	
12	Press <b>[ESC]</b> key. The display goes back to the edit window.	Edit-Prog Mdfy Copy Ctl	
13	Press <b>[ESC]</b> key.	Edit Posi Prog Sym Para	
14	Press <b>[F1]</b> (Yes) key if you desire to write the data to the flash ROM.	Flash Write ? Yes No	Press <b>[F2]</b> (No) key if you do not desire a writing.
15	'Please wait...' blinks while in the flash ROM writing process.	Flash Writing Flash ROM Please Wait...	* Do not turn off the controller during this process.
16	Now, it is completed to write the flash ROM. Return to the edit window by pressing <b>[ESC]</b> key.	Flash Complete!	

## Troubleshooting

If the connection does not work properly, check the following item.

Description	Measure
Communication connection with the controller is disabled.	Set the mode switch on the controller to "MANU" if it is on "AUTO" side.
"enb" is displayed on the LED.	For XSEL-P and PX controllers, set the teaching pendant changeover switch to the "left side" if it is on the "right side".



Quality and Innovation

## IAI Corporation

Head Office: 577-1 Obane Shimizu-KU Shizuoka City Shizuoka 424-0103, Japan  
TEL +81-54-364-5105 FAX +81-54-364-2589  
website: www.iai-robot.co.jp/

Technical Support available in USA, Europe and China

## IAI America, Inc.

Head Office: 2690 W. 237th Street, Torrance, CA 90505  
TEL (310) 891-6015 FAX (310) 891-0815  
Chicago Office: 110 East State Parkway, Schaumburg, IL 60173  
TEL (847) 908-1400 FAX (847) 908-1399  
Atlanta Office: 1220 Kennestone Circle, Suite 108, Marietta, GA 30066  
TEL (678) 354-9470 FAX (678) 354-9471  
website: www.intelligentactuator.com

## IAI Industrieroboter GmbH

Ober der Röth 4, D-65824 Schwalbach am Taunus, Germany  
TEL 06196-88950 FAX 06196-889524  
website: www.iai-gmbh.de

## IAI (Shanghai) Co., Ltd.

SHANGHAI JIAHUA BUSINESS CENTER A8-303, 808, Hongqiao Rd. Shanghai 200030, China  
TEL 021-6448-4753 FAX 021-6448-3992  
website: www.iai-robot.com

## IAI Robot (Thailand) Co., Ltd.

825 PhairojKijja Tower 7th Floor, Bangna-Trad RD., Bangna, Bangkok 10260, Thailand  
TEL +66-2-361-4458 FAX +66-2-361-4456  
website: www.iai-robot.co.th