

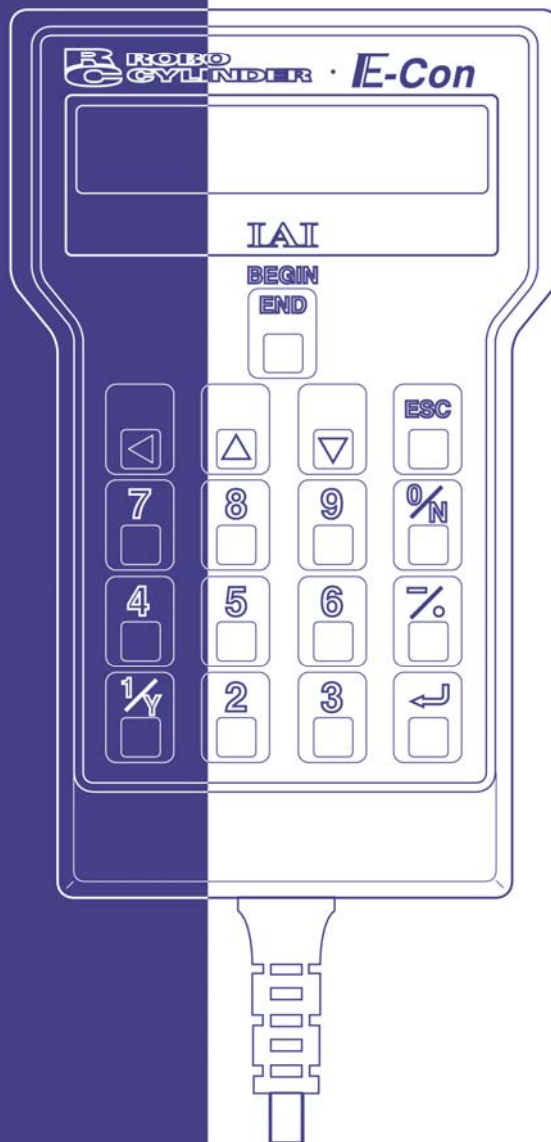

# Robo Cylinder Data Input Pendant RCA-P

Operating Manual Ver. 4.0





## Table of Contents

1. Foreword.....	1
2. Before You Begin.....	1
3. Safety Precautions.....	2
4. Warranty and Scope of Warranty.....	3
5. Application Environment.....	4
6. Functions and Specifications of Data Input Pendant.....	5
6-1 Specifications.....	5
6-2 External View.....	6
6-3 Description of Each Part.....	7
7. Connection With the Controller.....	9
7-1 Connection with the Data Input Pendant.....	9
7-2 How to Disengage the Data Input Pendant.....	9
8. Operation.....	10
8-1 Initial Screen During Power - UP.....	12
8-2 Controller Selection (when using multiple units).....	13
8-3 Operation Mode Selection.....	14
8-4 Edit/Teaching.....	15
8-4-1 Edit/Teach Screen.....	15
8-4-2 Position Data Table.....	16
8-4-3 Data Input.....	19
8-4-5 Add • Delete.....	24
8-4-5 Data Modification.....	29
8-5 Monitor.....	30
8-6 Error List.....	31
8-7 User Parameter.....	32
8-8 User Adjustment.....	34
8-9 End.....	35
9. Message Area.....	36
9-1 Warning Label Error (Code No. 000h – 07Fh).....	36
9-2 Data Input Pendant Message Level Error.....	37
9-3 Controller Error.....	37



## 1. Foreword

Thank you very much for purchasing the Data Input Pendant (RCA-P) for the Robo Cylinder Controller. Without knowing beforehand how to correctly use or operate the Data Input Pendant, not only will the user be unable to take full advantage of all the functions built into this product but the user might also inadvertently cause damage to the Controller or shorten its life. Please read this manual carefully as well as other manuals pertaining to the product to acquire an understanding of the proper method of handling and operating the controller. Keep this manual handy so that you can refer to the appropriate sections as the need arises.

For the actuator and controller to be used, be sure to refer to the Instruction Manuals attached to the products.

<p><b>Caution:</b> Do not edit position data while the actuator is operating by PLC, etc. Also, do not edit any position number not actually operated.</p>
--

## 2. Before You Begin

- (1) Please read this manual carefully to operate the controller properly.
- (2) You are not allowed to reproduce this manual or any portion thereof without permission.
- (3) For any handling and operating methods other than those described in this Instruction Manual, interpret them as "don't" or "can't."
- (4) We cannot accept any responsibility for possible damage resulting from the use of this manual.
- (5) We reserve the right to change the information contained in this manual without prior notice.

### 3. Safety Precautions

- (1) Use a genuine product specified by us for wiring between the actuator and controller.
- (2) Stand clear of the operating range of the machine when it is in motion or is ready to operate. Surround the system with safety partitions if there is a possibility that people can enter the area where the machine is being used.
- (3) When assembling, adjusting, or performing maintenance on the machine, always disengage the power supply to the controller. During work, display a sign stating work in progress where it is readily visible. Also, keep the power cable close to the operator so that another person cannot inadvertently switch on the power. Alternatively, lock the power plug or receptacle and direct the operator to hold the key or prepare a safety plug.
- (4) When more than one person is working on the system, agree on signals beforehand to ensure everyone's safety before beginning work. In particular, when doing work involving axis movement, always call out for everyone's safety regardless of whether power is ON or OFF, or the axis is to be mechanically driven or manually moved.
- (5) When the user needs to lengthen the cables, check the wiring carefully to make sure it is correct before turning the power ON since miswiring can lead to misoperation.

## **4. Warranty and Scope of Warranty**

The Data Input Pendant undergoes stringent testing before it is shipped from our factory. IAI provides the following warranty.

### **1. Warranty Period**

The warranty period shall be either the following period, whichever is reached first.

- 18 months after our shipment
- 12 months after delivery to the place designated by you

### **2. Scope of Warranty**

If within the period specified above, a breakdown occurs while operating the controller under normal conditions and is clearly the responsibility of the manufacturer, IAI will repair the unit at no cost. However, the following items are not covered by this warranty.

- Faded paint or other changes that occur naturally over time.
- Consumable components that wear out (such as a cable).
- Unit seems to be noisy or similar impressions that do not affect machinery performance.
- Damage resulting from improper handling or use.
- Damage resulting from user error or failure to perform proper maintenance.
- Damage resulting from the use of any part other than our genuine parts.
- Any alterations not authorized by IAI or its representatives.
- Damage caused by fire and other natural disasters or accidents.

The warranty pertains to the purchased product itself and does not cover any loss that might arise from a breakdown of the product. Any repairs will be done at our factory.

### **3. Service**

The purchase price of the product does not include programming or expenses for sending technicians to the customer's site. Even if the product is still under the warranty period, separate charges will be assessed for the following services.

- Inspection and maintenance.
- Technical guidance and technical training in operating instructions.
- Technical guidance and technical training on program-related matters such as program creation.

## 5. Application Environment

- In order to avoid breakdown, please do not apply any type of machinery impact onto the Data Input Pendant.
- Always hold onto the entire Data Input Pendant Body so that the Data Input Pendant Cable does not get pulled by unwanted cables.

**Caution:** This Data Input Pendant is designed exclusively for the IAI RC Controller, and should not be used to connect with other devices.

**Caution:** Regarding controller connection, please turn the controller front side port switch OFF before connecting to the controller.



## 6. Functions and Specifications of Data Input Pendant

Through the communication between the controller, the RC Data Input Pendant is designed to function as the Display Operation Unit to edit or display the data (common data, move point data, etc.) that is stored inside the controller.

It cannot be used for any operation related to axis movement.

LCD: Horizontal 16 characters Vertical 2 lines

### 6-1 Specifications

Item	Specification
Ambient Temperature & Humidity	Temperature: 0°~40°C Humidity: 85% RH or less * RH relative humidity
Operating Environment	Free of corrosive gas, especially, no excessive dust
Weight	380g
Cable Length	5m

## 6-2 External View

External Dimensions

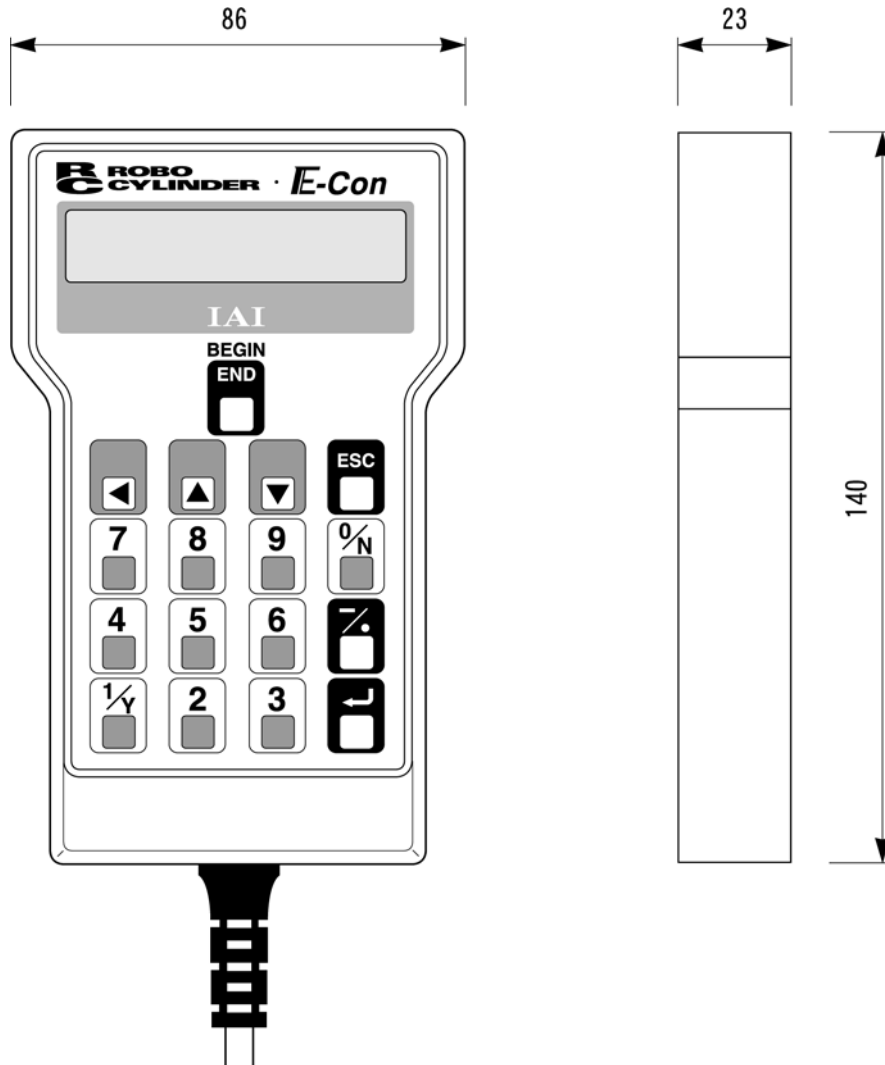

6-3 Description of Each Part

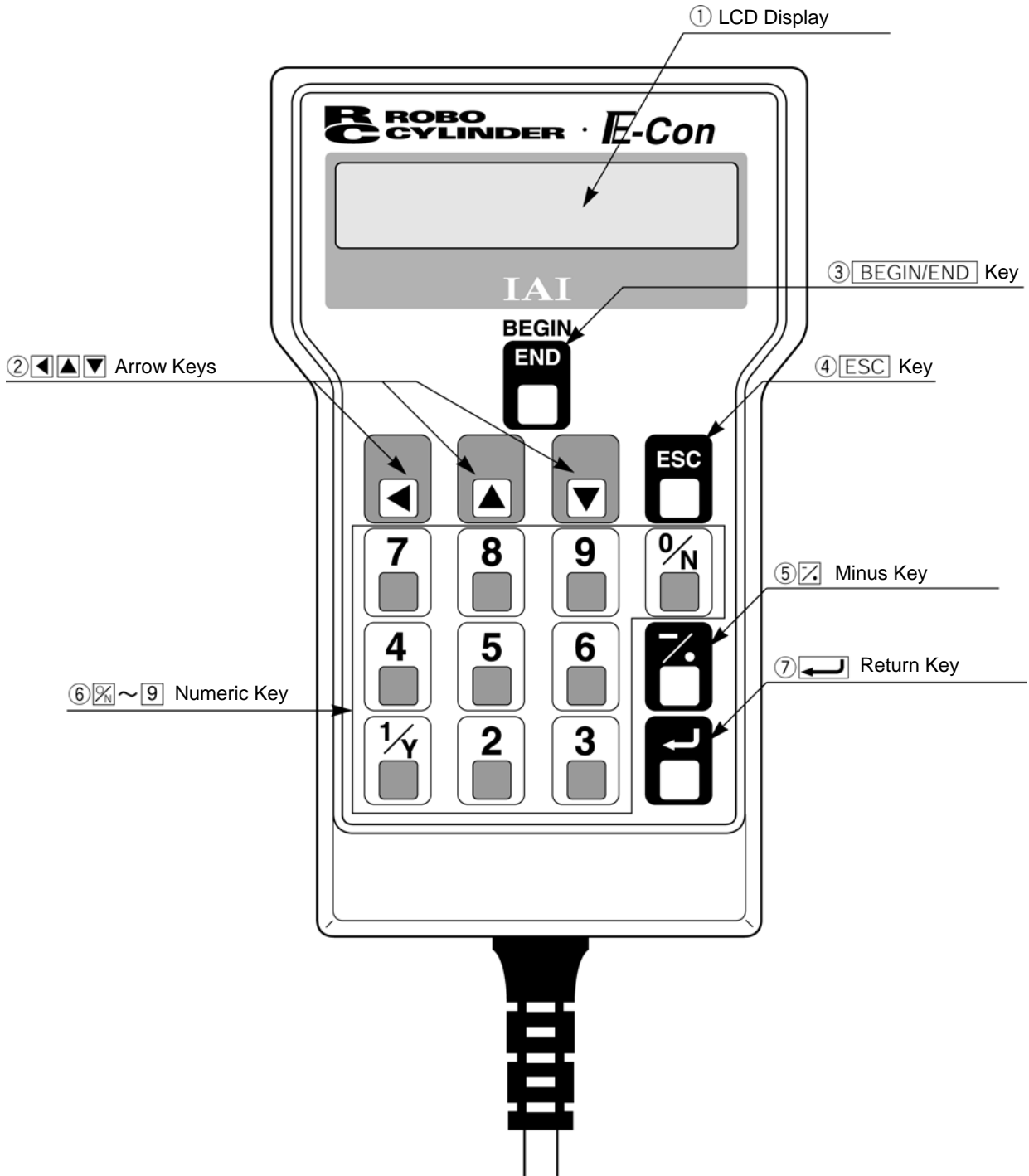

**(1) LCD Display**

This is a liquid crystal display with a maximum of horizontal: 16 characters per column, and vertical: 2 columns per row.

This displays edit and teaching contents of various set values.

**(2)    Arrow Key**

- This is used for selection of the mode, the contents of data and changing position No.

**(3)  Key**

- Execution of Data Input Pendant configuration or axis reconnection.

By pressing this key for more than 2.5 seconds, the screen will change into the "BEGIN/END" screen and you will be able to reconnect the axis and execute Data Input Pendant configuration.

- If entering data via key pad, you may cancel midway using this key.

- You may clear error warning.

- When an error occurs, a message for this error will appear at the very bottom of the display screen.

Use this key to clear the error and to clear this message.



**(4)  Key**



- Return to the display of a previous screen

The Data Input Pendant operation has a several-layer nested structure. Using this key can return the user to one layer above (previous screen).

When you don't understand the operation, undo the operation by pressing the ESC Key.

**(5)  (Minus) Key**

- Position Table Column: When you push this in an area such as positioning width which allows minus input, the key functions as the "-" (minus), and the rest as "." (point). When you input either  or  in the beginning of the number, within the proper area, the key will automatically recognize it as 0.

**(6) ~ (Numeric) Key**

- This key is used for numeric input.

**(7)  (Return) Key**

- This is used for data input and operation confirm.

## 7. Connection With the Controller

### 7-1 Connection with the Data Input Pendant

- (1) Connect the Data Input Pendant Cable to the "PORT IN" connector which is located on the front of the controller. Always turn OFF the controller Port Switch first before connecting.  
(In a case of ERC, there is no Port Switch, please power off the unit.)

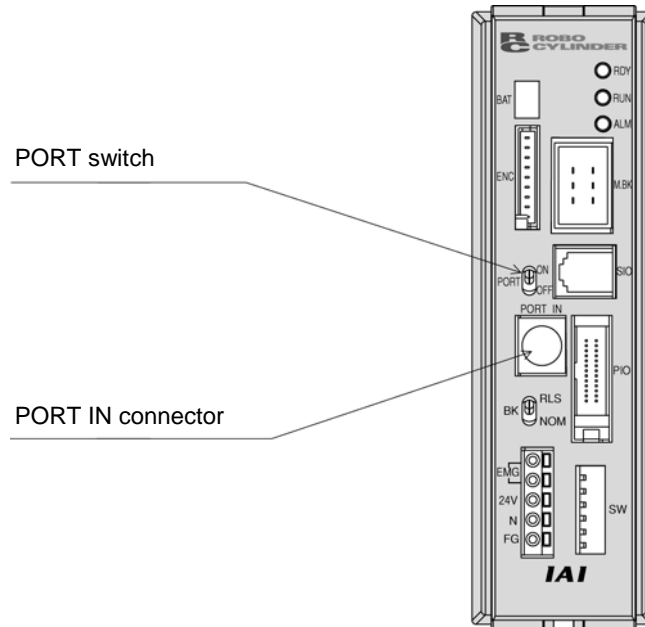

- (2) After connecting, turn the controller PORT Switch ON.

### 7-2 How to Disengage the Data Input Pendant

Hold down the BEGIN/END Key which is located in the upper of the key pad. Select "Complete" to finish. Afterwards, turn the controller front SW side to OFF, and remove the Data input pendant connector.

Operation:

1. Hold down the BEGIN/END Key for more than 2.5 seconds.
2. Use the Arrow Key to select "Complete" Screen, and then press the Return Key.
3. Turn the RC Controller PORT SW OFF.
4. Remove the Data Input Pendant connector.

## 8. Operation

The Data Input Pendant operation has the following overall tree structure.

The menus in this tree structure differ according to the controller type/version or Data Input Pendant version. For details, refer to the Instruction Manual of each controller. The following indicates the case of ERC.

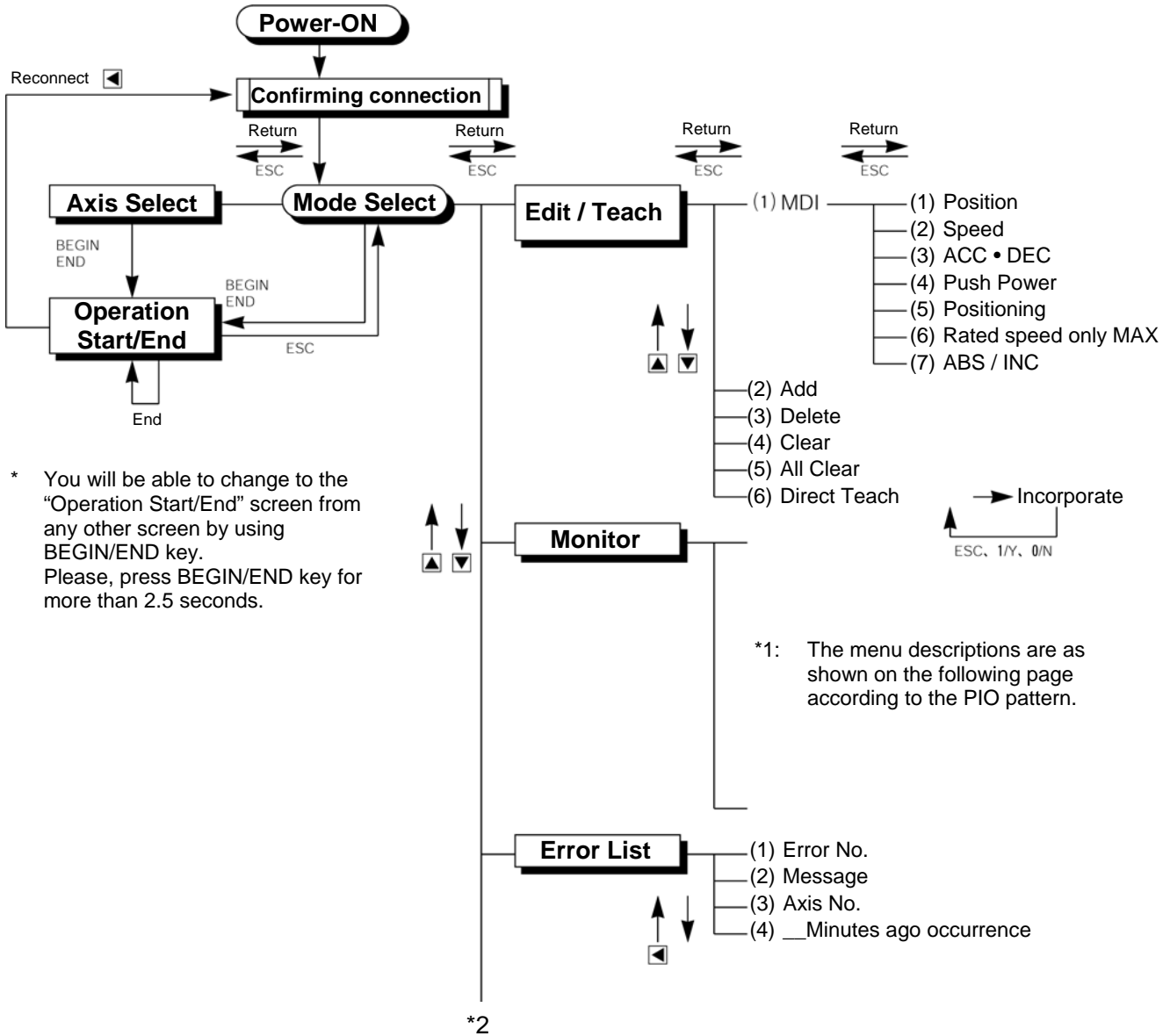

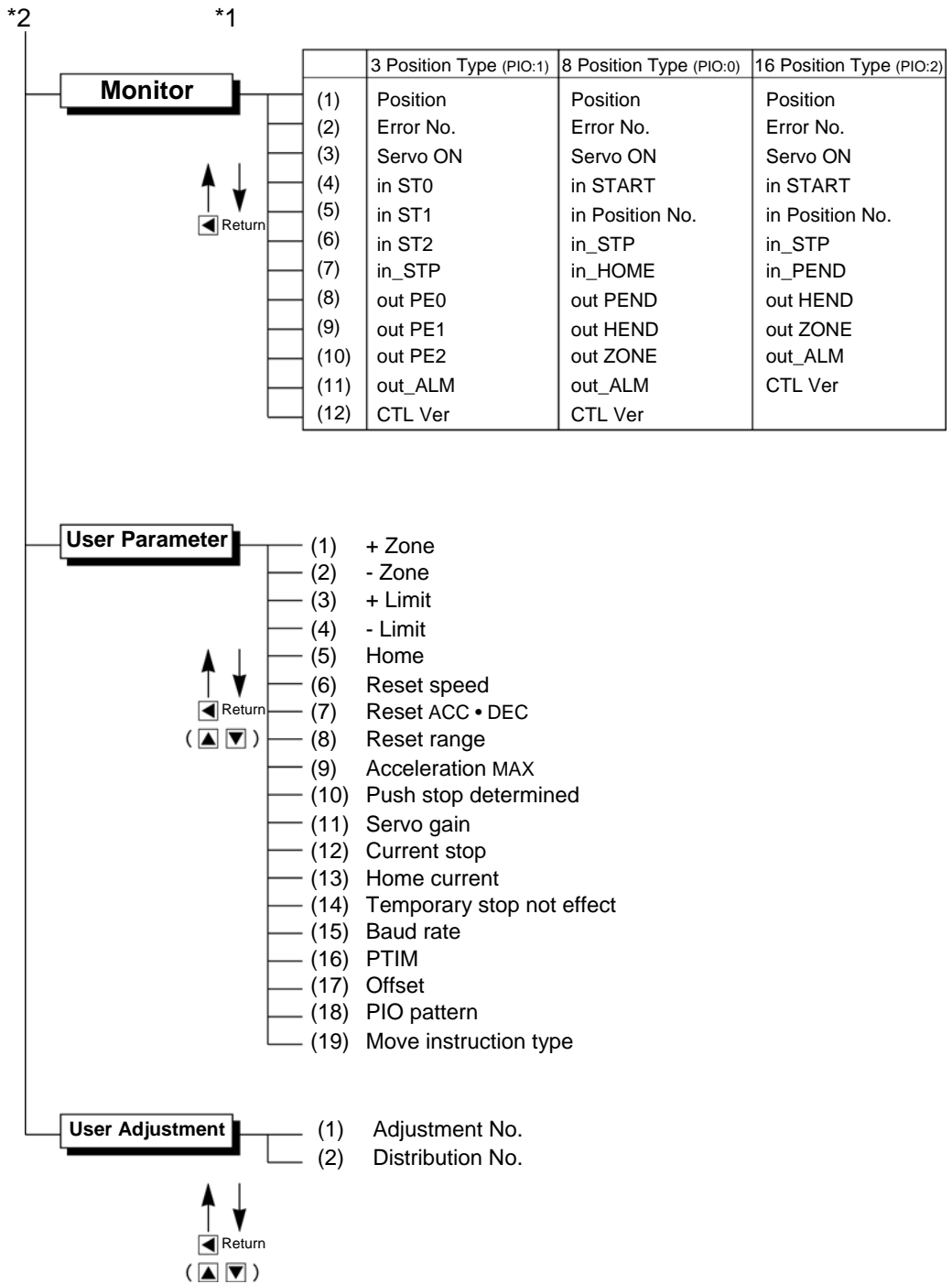

## 8-1 Initial Screen During Power - UP

When power is connected to the controller and the controller PORT switch is ON, power is supplied to the Data Input Pendant and operation starts.

Upon power-on, the LCD display screen (hereinafter called the "screen") displays the Data Input Pendant software version as follows:

Confirming connection IAI RC DU V.1.66
---

Once the controller connection has been completed, the screen automatically moves to the Mode Select screen in a defined period of time.



## 8-2 Controller Selection (when using multiple units)

In case of multiple units connected serially via the communication line, the axis selection screen will be displayed. For a single unit, since there is no need to select the axis, the first screen below will not appear (refer to Section 8.3 entitled Operational Mode Selection of this manual). The content explained here will be based on operation of the selected axis (controller). In addition, the controller can connect up to 16 units.

Axis Select  
\* Axis No. 00



Axis Select  
\* Axis No. 01



Axis number



Axis Select  
\* Axis No. 02



•  
•  
•

Using the ▲▼ Keys, select the data inputting axis (controller), and determine with the Return Key. Only the connecting axis will be displayed.

**Caution:** If power is supplied with the PORT switch ON and power is present on the Data Input Pendant, only powered controllers will be detected.

The content explained hereinafter will be based on operation against selected axis (controller).

### 8-3 Operation Mode Selection

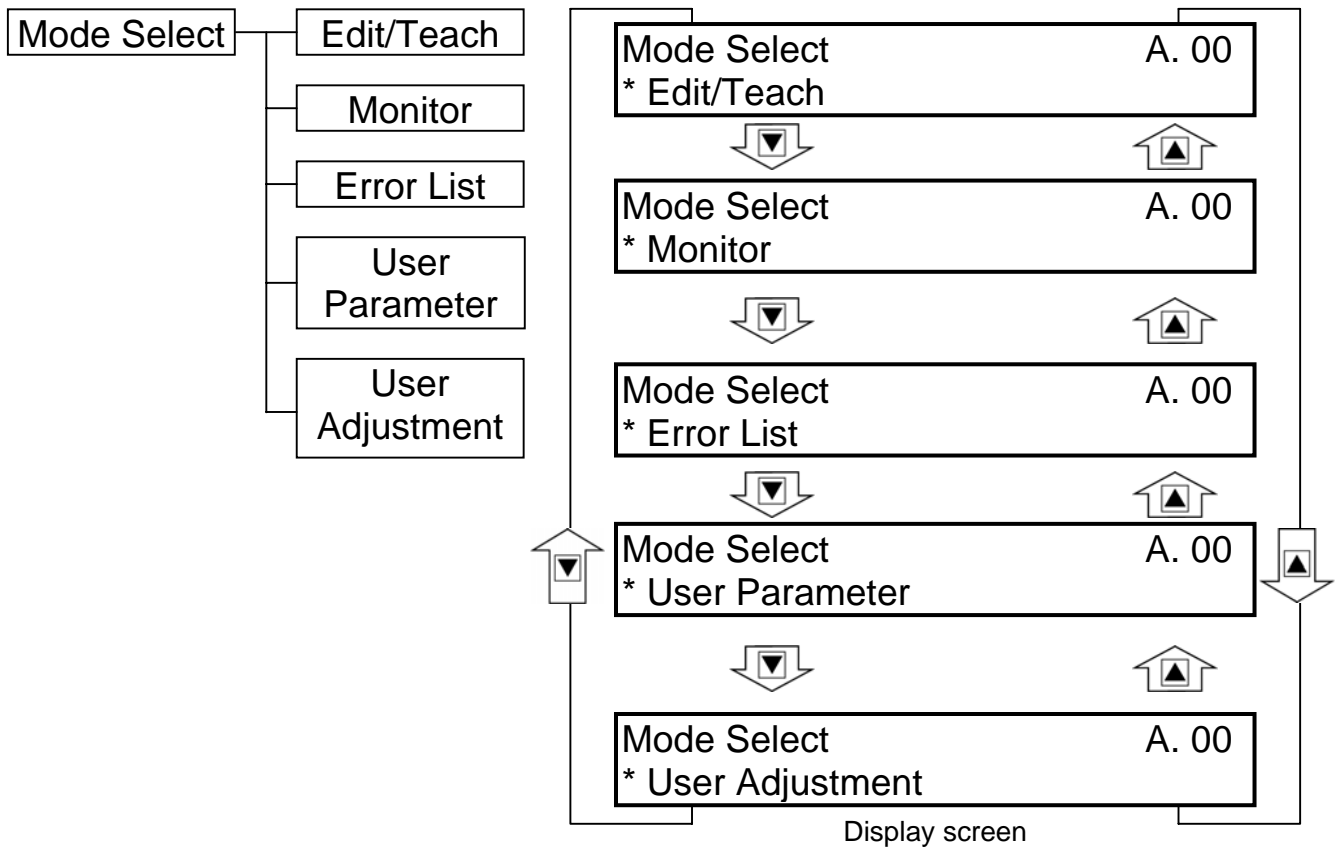

For the modes, select one of the 5 options as it appears on the above screen.  
 To select, move the cursor to the mode desired and confirm using the Return Key.

#### Category of Modes

- |                      |   |
|----------------------|---|
| 1. * Edit/Teach      | Edit and numeric input function for position data table   |
| 2. * Monitor         | RC Controller status display  |
| 3. * Error list      | Alarm content detailed display  |
| 4. * User Parameter  | Setting of axis zone signal output range and axis   |
| 5. * User Adjustment | Setting for enabling or disabling of temporary stop (hold) input and actuator integrated RC controller. |

## 8-4 Edit/Teaching

### 8-4-1 Edit/Teach Screen

When “\*Edit/Teach” is selected on the Mode Select screen, the Edit/Teach screen is displayed.

The Edit/Teach screen has the 6 items as follows:

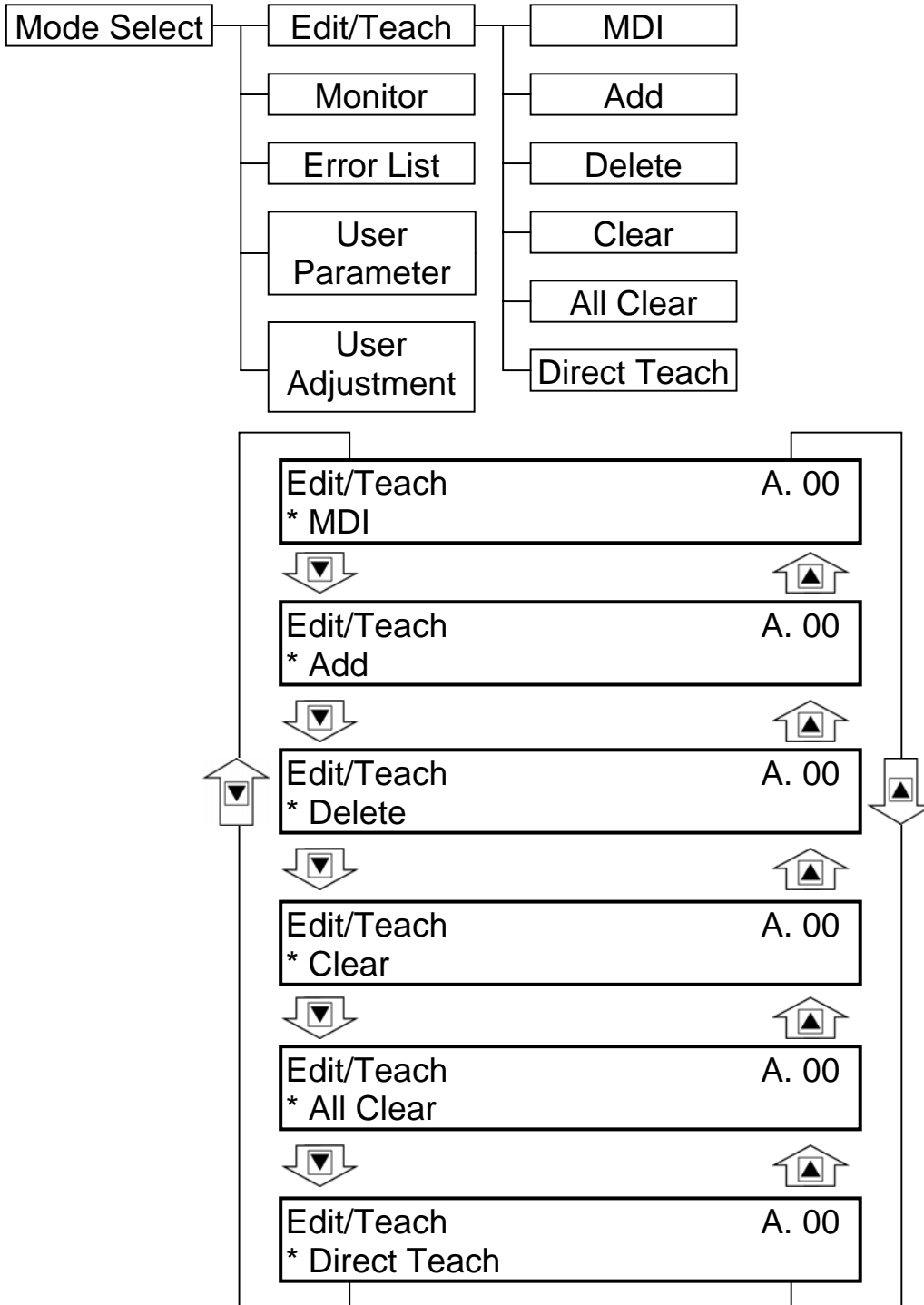

You can change the screens by using the arrow keys (▲▼) and press the return key.

- \* MDI: Numerically inputs the position data directly from the ten numerical keys (input example: Page 20 in this manual).
- \* Add: Adds the position data into the assigned position data number (input example: Page 25 in this manual).
- \* Delete: Deletes position data (input example: Page 26 in this manual).
- \* Clear: Resets the position data (input example: Page 27 in this manual).
- \* All Clear: Resets all of the 16 position data (input example: Page 28 in this manual).  
The position data table will display by selecting and determining MDI
- \* Direct Teach: Turns off the servo and places the slider at the desired position by moving it by hand and incorporates the position into the position data (input example: Page 23 in this manual).

### 8-4-2 Position Data Table

When MDI is selected and determined, the contents of the position data table are displayed.

The position data table can be changed among the forms of 3 positions (No. 0 - No. 2), 8 Positions (No.1 - No.7) and 16 positions (No.0 - No.15) according to PIO pattern setting of the user parameter.





No.	Position	Speed	ACC • DEC	Push %	Range	ACC MAX	ABS/INC
0	*	*mm/s	*G	*%	*mm	*	0
1	*	*mm/s	*G	*%	*mm	*	0
2	*	*mm/s	*G	*%	*mm	*	0
3	*	*mm/s	*G	*%	*mm	*	0
4	*	*mm/s	*G	*%	*mm	*	0
5	*	*mm/s	*G	*%	*mm	*	0
6	*	*mm/s	*G	*%	*mm	*	0
7	*	*mm/s	*G	*%	*mm	*	0
8	*	*mm/s	*G	*%	*mm	*	0
9	*	*mm/s	*G	*%	*mm	*	0
10	*	*mm/s	*G	*%	*mm	*	0
11	*	*mm/s	*G	*%	*mm	*	0
12	*	*mm/s	*G	*%	*mm	*	0
13	*	*mm/s	*G	*%	*mm	*	0
14	*	*mm/s	*G	*%	*mm	*	0
15	*	*mm/s	*G	*%	*mm	*	0

Position Data Table

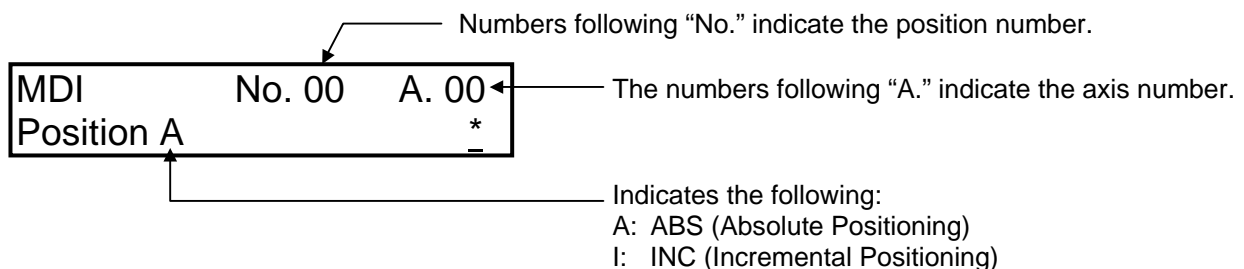
Use either the Return Key or ◀ Key to execute transfer of the content. Use either of ▲▼ Keys for position number changes. In the display screen, only the single content of one position number will be displayed.



The following are the descriptions of the setting items:

- (1) Position: The desired move location from home in millimeters.
- Absolute Positioning:  
Moves the actuator to the desired location in reference to the home location. Inputting negative values is not possible.
  - Relative Positioning:  
Moves the actuator to the desired position in reference to the current position. Inputting negative values is possible. In this case (during negative direction of the display coordinate), first select Relative Positioning using (7) ABS/INC.
  - \* By pressing the  Key once from the Position Input Screen will move the screen to ABS/INC Input Screen.

**Caution:** There are cases when the input value may be rounded off to the least common denominator multiple of the controller.

- (2) Speed - The speed when moving the actuator (mm/sec).  
The default value will depend on the actuator type.
- (3) Acc/Dec - The acceleration/deceleration setting for the move to the corresponding position (in G's).  
The default value will depend on the actuator type.
- (4) Push% - Selects the positioning mode or push mode.  
The default value is set as 0.  
0: Positioning Mode (normal movement)  
Besides 0: Push Mode (%)
- In case of push mode, data number is the servo motor current control value during push.  
Uses a value that matches the actuator type with a maximum value of 70%.

- (5) Range - As for the range, depending on the setting in the push as either 0 or other than 0, this function will vary.
- (A) Push = 0 (Positioning Mode)
- The positioning mode uses range value as a location to turn ON the position complete output prior to reaching the actual position.
  - The default value will depend on the actuator type. (see diagram A).
- (B) Push  $\neq$  0 (Push Mode)
- The push mode uses the range value as the distance of the push.
  - When the push direction is towards home, enter a negative value in the range column.

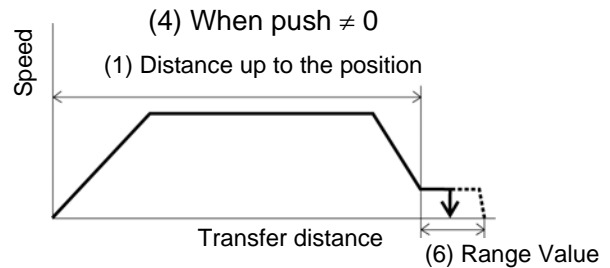
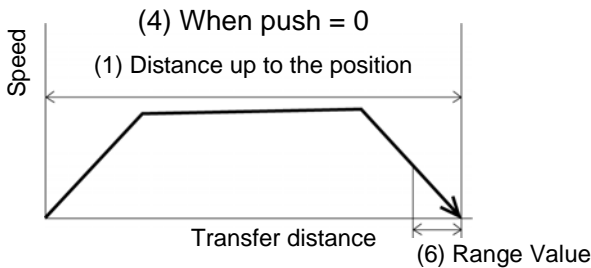

(6) MAX Acceleration

- Selects either the assigned acceleration or the maximum acceleration. Inputs are either 1 or 0. The default value is set as 0.
- 0: Assigned acceleration  
The value placed in (3) will be used as the actual acceleration value and deceleration value.
- 1: Maximum acceleration  
This will automatically utilize the maximum acceleration matched to the load.  
Deceleration remains as the assigned value in (3).

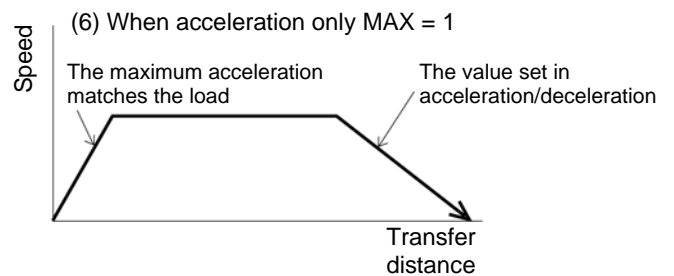
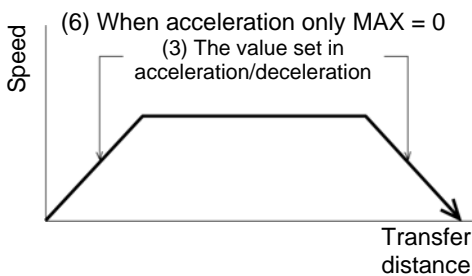

(7) ABS/INC - Select either the absolute or incremental positioning.

- 0: Absolute positioning (ABS)
- 1: Incremental positioning (INC)
- The default value is 0, absolute positioning (ABS).

### 8-4-3 Data Input

There are two methods of inputting the position data.

(1) MDI numeric input:

Method of numerically inputting the position data directly from the ten numerical keys of the Data Input Pendant.

(2) Direct Teach:

Method of turning off the servo, placing the slider at the desired position by moving it by hand and teaching the position (current position) to the position data table.

**Caution:** When the position data is first input by the method of Direct Teach after power-on or alarm raising, it is required to have homed the actuator in advance.  
The Data Input Pendant has no function of homing the actuator.  
Execute Direct Teach after homing with the PLC in advance.

(1) MDI Numeric Input

Position No. 0	Absolute positioning mode Position 0mm
Position No. 1	Absolute positioning mode Position 50mm, Speed 100mm/s, ACC • DEC 0.1G Range 0.2mm, ACC MAX 1
Position No. 2	Absolute push mode Position 80mm, Speed 100mm/s, ACC • DEC 0.1G Push 40%, Range 5mm
Position No. 3	Incremental positioning mode Position 10mm, speed 20mm/s

Data not assigned utilizes default value. The example here is based on initial status during shipment (when data is all clear).

You may input data from position data table similar to the table below.

Position Data Table

No.	Position	Speed	ACC • DEC	Push %	Range	ACC MAX	ABS/INC
0	0.00	125 mm/s	0.20 G	0%	0.10mm	0	0
1	50.00	100 mm/s	0.10 G	0%	0.20mm	1	0
2	80.00	100 mm/s	0.10 G	40%	5.00mm	0	0
3	10.00	20 mm/s	0.20 G	0%	0.10mm	0	1

Input the data inside the thick line (see above table). The default values will be used for the data outside the thick-lined frame. By inputting the position data, the default value will automatically input.

The default values (Speed, ACC • DEC and Range) will vary according to actuator machine type (in this example: RSA Low speed type).

<b>Mode Select</b> * Edit/Teach	A. 00	Using the ▲▼ Key in the Mode Select Screen, select Edit/Teach and choose using the Return Key.
------------------------------------	-------	--

<b>Edit/Teach</b> * MDI	A. 00	Using the ▲▼ Key in the Edit/Teach Screen, select MDI and choose using the Return Key.
----------------------------	-------	--

Input using position number 0.

MDI	No. 00	A. 00	The screen will turn into the Input Screen for Position.
Position A		*	
		_	

MDI	No. 00	A. 00	Using the Numeric Key, press 0 and the Return Key.
Position A		0_	



MDI	No. 00	A. 00
Speed	125	mm/s

The screen will turn into the Input Screen for Speed. The default value will be utilized as is. Since other data will use the default value, input for position number 0 will end here.

Next, position number 1 input will be executed.

Input using position number 1

MDI	No. 01	A. 00
Position A	<u>1</u>	*

↑  
Position number 1

Press the  Key to advance position number to 1.

MDI	No. 01	A. 00
Position A		<u>50</u>

The screen will turn into the Input Screen for Position. Use the Numeric Keys to input 50 and then, press the Return Key.

MDI	No. 01	A. 00
Speed	<u>100</u>	mm/s

The screen will turn into the Input Screen for Speed. Use the Numeric Keys to input 100 and then, press the Return Key.

MDI	No. 01	A. 00
ACC•DEC	<u>0.1</u>	G

The screen will turn into the Input Screen for ACC • DEC. Use the Numeric Keys to input 0.1 and then, press the Return Key.

MDI	No. 01	A. 00
Push %	<u>0</u>	%

The screen will turn into the Input Screen for Push %. The default value will be utilized as is, so press the Return Key.

MDI	No. 01	A. 00
Range		<u>0.2</u> mm

The screen will turn into the Input Screen for Range. Use the Numeric Keys to input 0.2 and then, press the Return Key.

MDI	No. 01	A. 00
ACC MAX	<u>1</u>	

The screen will turn into the Input Screen for ACC MAX. Use the Numeric Key to input 1 and then, press the Return Key.

MDI	No. 01	A. 00
ABS → 0	INC → 1	<u>0</u>

The screen will turn into the Input Screen for ABS/INC. The default value will be utilized as is, so press the Return key.

Input for position number 1 will end here.

Next, position number 2 input will be executed.

Input using position number 2

MDI	No. 02	A. 00
Position A		*
		-

↑  
Position number 2

Press the  Key to advance position number to 2.

MDI	No. 02	A. 00
Position A		80

The screen will turn into the Input Screen for Position. Use the Numeric Keys to input 80 and then, press the Return Key.

MDI	No. 02	A. 00
Speed	100	mm/s

The screen will turn into the Input Screen for Speed. Use the Numeric Keys to input 100 and then, press the Return Key.

MDI	No. 02	A. 00
ACC•DEC	0.1	G

The screen will turn into the Input Screen for ACC • DEC. Use the Numeric Keys to input 0.1 and then, press the Return Key.

MDI	No. 02	A. 00
Push %	40	%

The screen will turn into the Input Screen for Push %. Use the Numeric Keys to input 40 and then, press the Return Key.

MDI	No. 02	A. 00
Range		5mm

The screen will turn into the Input Screen for Range. Use the Numeric Key to input 5 and then, press the Return Key.

MDI	No. 02	A. 00
ACC MAX	0	

Input for position number 2 will end here. Next, position number 3 input will be executed.

Input using position number 3

MDI	No. 03	A. 00
Position A		*
		-

↑  
Position number 3

Press the  Key to advance position number to 3. The screen will turn into the Input Screen for Position.

Input using MDI

MDI	No. 03	A. 00
ABS → 0	INC → 1	1

Press the  Key to change screen into ABS/INC Display Screen. Use the Numeric Key to input 1 and then, press the Return Key.

MDI	No. 03	A. 00
Position I		10.00

The screen will turn into the Input Screen for Position. Use the Numeric Keys to input 10 and then, press the Return Key.

↑  
INC  
(Relative positioning)

MDI	No. 03	A. 00
Speed	20	mm/s

The screen will turn into the Input Screen for Speed. Use the Numeric Keys to input 20 and then, press the Return Key.

Input for MDI will end here.

(2) Direct Teach

By this method, the slider or rod is moved by hand to place it at the desired position and the current position is incorporated into the position data table.

In this example, data is input for position number 4 by Direct Teach.

Mode Select * Edit/Teach	A. 00
-----------------------------	-------

Using the ▲▼ Key in the Mode Select Screen, select Edit/Teach and choose using the Return Key.

Edit/Teach * Direct Teach	A. 00
------------------------------	-------

Using the ▲▼ Key in the Edit/Teach Screen, select Direct Teach and choose using the Return Key.

Direct Teach Servo OFF	A. 00 51.23F
---------------------------	-----------------

The servo is turned OFF and the current position is displayed. Under this condition, move the slider or rod by hand to a desired position.

Displays the current position.  
\* Although this is displayed even when homing is incomplete, it is not an accurate value.

(In the case of the actuator with brake, release the brake.)

After determining the desired position, press the Return key.

Position number 4

Incorporate? *	No. 04 Y → 1 N → 0	A. 00
-------------------	-----------------------	-------

Change the position number to 4 using ▲▼ keys. Press 1 on the numeric key.

Displays the old position data. It is not the desired position determined in the previous screen.

(If the slider or rod moves before pressing 1, determine a desired position again.)

To cancel the data, press 0.

Direct Teach Servo OFF	A. 00 51.23F
---------------------------	-----------------

In either case, the screen returns to the previous screen.

Mode Select * Edit/Teach	A. 00
-----------------------------	-------

Press the ESC key twice to return the screen to the Mode Select screen.

**Caution:** Input any data (speed, acceleration/deceleration, etc.) other than position by MDI.  
When the position data is first input by the method of Direct Teach after power-on or alarm raising, it is required to have homed the actuator in advance.  
The Data Input Pendant has no function of homing the actuator.  
Execute Direct Teach after homing with the PLC in advance.

### 8-4-5 Add • Delete

In this section, we will give specific examples of how to add • delete and clear data in the position table.

- (1) Add: Adds the position data into the assigned position data number location.
- (2) Delete: Deletes assigned position data.
- (3) Clear: Resets the assigned position data.
- (4) All Clear: Resets all of 16 position data.

(1) Add:

The Add operation procedure is explained below. A blank row is inserted into any position number. In this example, a blank row is inserted into position number 2.

The position data table becomes as shown below.

No.	Position	Speed	ACC • DEC	Push %	Range	ACC MAX	ABS/INC
0	0.00	125 mm/s	0.20 G	0%	0.10mm	0	0
1	50.00	100 mm/s	0.10 G	0%	0.20mm	1	0
2	80.00	100 mm/s	0.10 G	40%	5.00mm	0	0
3	10.00	20 mm/s	0.20 G	0%	0.10mm	0	1



No.	Position	Speed	ACC • DEC	Push %	Range	ACC MAX	ABS/INC
0	0.00	125 mm/s	0.20 G	0%	0.10mm	0	0
1	50.00	100 mm/s	0.10 G	0%	0.20mm	1	0
2	*	* mm/s	* G	* %	* mm	*	0
3	80.00	100 mm/s	0.10 G	40%	5.00mm	0	0
4	10.00	20 mm/s	0.20 G	0%	0.10mm	0	1

Mode Select * Edit/Teach	A. 00
-----------------------------	-------

In the Mode Select Screen, using the ▲▼ Keys, select Edit/Teach and then, press the Return Key.

Edit/Teach * Add	A. 00
---------------------	-------

In the Edit/Teach screen, using the ▲▼ Keys, select Add and then, press the Return Key.

Add?	No. 2	A. 00
	80.00 Y → 1 N → 0	

Using the ▲▼ Keys, change the position number into 2.

Add?	No. 2	A. 00
	* Y → 1 N → 0	

Pressing 1 on the Numeric Key will insert a blank point and then, the screen will return to the Edit/Teach Screen.

Edit/Teach * Add	A. 00
---------------------	-------

Mode Select * Edit/Teach	A. 00
-----------------------------	-------

Press the ESC Key once to return the screen back to Mode Select Screen.

(2) Delete:

The Delete operation procedure is explained below. The data of any position number is deleted. In this example, the data of position number 2 is deleted.

The position data table becomes as shown below.

No.	Position	Speed	ACC • DEC	Push %	Range	ACC MAX	ABS/INC
0	0.00	125 mm/s	0.20 G	0%	0.10mm	0	0
1	50.00	100 mm/s	0.10 G	0%	0.20mm	1	0
2	*	* mm/s	* G	* %	* mm	*	0
3	80.00	100 mm/s	0.10 G	40%	5.00mm	0	0
4	10.00	20 mm/s	0.20 G	0%	0.10mm	0	1



No.	Position	Speed	ACC • DEC	Push %	Range	ACC MAX	ABS/INC
0	0.00	125 mm/s	0.20 G	0%	0.10mm	0	0
1	50.00	100 mm/s	0.10 G	0%	0.20mm	1	0
2	80.00	100 mm/s	0.10 G	40%	5.00mm	0	0
3	10.00	20 mm/s	0.20 G	0%	0.10mm	0	1

Mode Select	A. 00
* Edit/Teach	

In the Mode Select Screen, using the ▲▼ Keys, select Edit/Teach and then, press the Return Key.

Edit/Teach	A. 00
* Delete	

In the Edit/Teach screen, using the ▲▼ Keys, select Add and then, press the Return Key.

Delete?	No. 2	A. 00
*	Y → 1	N → 0

Using the Keys, change the position number into 2. Pressing 1 on the Numeric Key will delete position number 2 and then, the screen will return to the Edit/Teach Screen. To cancel, press 0. In either case, the screen will return to the previous screen.

Edit/Teach	A. 00
* Delete	

Mode Select	A. 00
* Edit/Teach	

Press the ESC Key once to return the screen back to Mode Select Screen.

(3) Clear:

The Clear operation procedure is explained below. The data of any position number is cleared.

In this example, the data of position number 1 is cleared.

The position data table becomes as shown below.

No.	Position	Speed	ACC • DEC	Push %	Range	ACC MAX	ABS/INC
0	0.00	125 mm/s	0.20 G	0%	0.10mm	0	0
1	50.00	100 mm/s	0.10 G	0%	0.20mm	1	0
2	80.00	100 mm/s	0.10 G	40%	5.00mm	0	0
3	10.00	20 mm/s	0.20 G	0%	0.10mm	0	1



No.	Position	Speed	ACC • DEC	Push %	Range	ACC MAX	ABS/INC
0	0.00	125 mm/s	0.20 G	0%	0.10mm	0	0
1	*	* mm/s	* G	* %	* mm	*	0
2	80.00	100 mm/s	0.10 G	40%	5.00mm	0	0
3	10.00	20 mm/s	0.20 G	0%	0.10mm	0	1

Mode Select A. 00  
\* Edit/Teach

In the Mode Select Screen, using the ▲▼ Keys, select Edit/Teach and then, press the Return Key.

Edit/Teach A. 00  
\* Clear

In the Edit/Teach screen, using the ▲▼ Keys, select Add and then, press the Return Key.

Position number 1 →

Clear? No. 01 A. 00  
50.00 Y → 1 N → 0

Using the ▲▼ Keys, change the position number into 2. Pressing 1 on the Numeric Key will clear position number 1 and then, the screen will return to the Edit/Teach Screen. To cancel, press 0.

↑ Position data for position number 1

In either case, the screen will return to the previous screen.

Edit/Teach A. 00  
\* Clear

Mode Select A. 00  
\* Edit/Teach

Press the ESC Key once to return the screen back to Mode Select Screen.

(3) All Clear:  
The data of all the position numbers is cleared.

The position data table becomes as shown below.

No.	Position	Speed	ACC • DEC	Push %	Range	ACC MAX	ABS/INC
0	0.00	125 mm/s	0.20 G	0%	0.10mm	0	0
1	50.00	100 mm/s	0.10 G	0%	0.20mm	1	0
2	80.00	100 mm/s	0.10 G	40%	5.00mm	0	0
3	10.00	20 mm/s	0.20 G	0%	0.10mm	0	1



No.	Position	Speed	ACC • DEC	Push %	Range	ACC MAX	ABS/INC
0	*	* mm/s	* G	* %	* mm	*	0
1	*	* mm/s	* G	* %	* mm	*	0
2	*	* mm/s	* G	* %	* mm	*	0
3	*	* mm/s	* G	* %	* mm	*	0

Mode Select A. 00  
\* Edit/Teach

In the Mode Select Screen, using the ▲▼ Keys, select Edit/Teach and then, press the Return Key.

Edit/Teach A. 00  
\* All Clear

In the Edit/Teach Screen, using the ▲▼ Keys, select All Clear and then, press the Return Key.

All Clear? A. 00  
Y → 1 N → 0

Pressing 1 on the Numeric Key will clear all data and then, the screen will return to the Edit/Teach Screen. To cancel, press 0.

In either case, the screen will return to the previous screen.

Edit/Teach A. 00  
\* All Clear

Mode Select A. 00  
\* Edit/Teach

Press the ESC Key once to return the screen back to Mode Select Screen.



### 8-4-5 Data Modification

You may write over all of the position data.

- (1) MDI numeric input:  
Input the position data directly from the ten numerical keys.
- (2) Direct Teach:  
Turns the servo OFF, manually move the slider to the desired location, and read that location into the position table.

During data modification, carry out operation carefully as shown below.

- \* As for MDI numeric input, only the overwritten items input by the ten numerical keys will be modified.
- \* As for Direct Teach, the position data will be updated when the current position is read by the Return key. There is no effect on any other items such as the speed.
- \* Once the position data has been cleared, the cleared data no longer remains anywhere. Therefore, when the position data is registered next time, the Positioning Mode and the Absolute Positioning are selected by default.

When the position data of the Push Mode or the Relative Positioning is cleared and registered again, be sure to check all the items of the position data and input necessary data.

## 8-5 Monitor

The I/O status or current position is displayed.

The displayed menu differs according to the controller type. In the case of RCP2/ERC, it also differs according to the PIO pattern.

Mode Select * Monitor	A. 00	In the Mode Select Screen, using the ▲▼ Keys, select Monitor and then, press the Return Key. Select the displayed item using the Return key or ◀ key. Use the ▲▼ Keys to change the axis number.
Monitor Pos	A. 00 0.00N mm	Displays the current position.
Monitor Error No. 000	A. 00	Displays the error code number.
Monitor Servo ON	A. 00	Displays the ON/OFF status of servo.
Monitor in Start	A. 00 OFF	Displays the ON/OFF status of start input.
Monitor in Pos No.	A. 00 00	Displays the assigned position number.
Monitor in_RES	A. 00 ON	Displays the ON/OFF status of reset input. (RCS, E-Con)
Monitor in SON	A. 00 00	Displays the ON/OFF status of servo ON input. (RCS, E-Con)
Monitor in_STP	A. 00 ON	Displays the ON/OFF status of temporary stop (hold) input.
Monitor out Pos No.	A. 00 00	Displays the complete position number.
Monitor out PEND	A. 00 ON	Displays the ON/OFF status of positioning complete output.
Monitor out HEND	A. 00 00	Displays ON if homing is completed or OFF if homing is not completed.

Monitor out_ZONE	A. 00 ON	Displays ON/OFF status of zone output.
Monitor out_ALM	A. 00 ON	Displays ON/OFF status of alarm output.
Mode Select * Monitor	A. 00	Press the ESC Key once to return the screen back to Mode Select Screen.

## 8-6 Error List

The screen displays the nature of the error having occurred after the Data Input Pendant connection.

Mode Select * Error List	A. 00	In the Mode Select Screen, using the ▲▼ Keys, select Edit/Teach and then, press the Return Key. Select the displayed item using the Return key or ◀ key.
Error List Error No.	List No. 0E8	0 Displays the error code number.
Error List A, B Phase	List No. Disconnection	0 Displays the error name.
Error List Axis No.	List No. 00	0 Displays the ON/OFF status of servo.
Error List	List No. 1 Min	0 Displays how many minutes ago the error occurred.
Mode Select * Error List	A. 00	Press the ESC Key once to return the screen back to Mode Select Screen.

## 8-7 User Parameter

The User parameter assigns zone and soft limit ranges, actuator attributes and home direction. Zone and soft limit are set within  $\pm 9999.99$  (input unit: mm).

Home and servo parameters are determined by the actuator. Each setting for initial setting value parameters is the registered default value for position data during teaching.

Mode Select * User Parameter	A. 00	In the Mode Select Screen, using the ▲▼ Keys, select User Parameter and then, press the Return Key. Select the displayed item using the Return key or ▲▼ key. To change the value, use the Numeric Key for input and then, press the Return Key.
User Para + Zone	A. 00 150.30mm	Displays the zone limit +side.
User Para - Zone	A. 00 -0.30mm	Displays the zone limit -side.
User Para + Limit	A. 00 150.30mm	Displays the soft limit + side.
User Para - Limit	A. 00 -0.30mm	Displays the soft limit - side.
User Para Home (CWO CCW1)	A. 00 1	Displays the assigned position number.
User Para Initi. Vel	A. 00 125mm/s	Displays the initial velocity value.
User Para Initi. ACC	A. 00 0.20G	Displays the initial ACC • DEC value.
User Para Range	A. 00 0.10mm	Displays initial positioning width value.
User Para ACC (1: MAX)	A. 00 0	Displays the initial ACC MAX value.
User Para Push Comp	A. 00 255ms	Displays the push stop determination time.

User Para Servo Gain	A. 00 <u>6</u>	Displays the number of the servo gain.
-------------------------	-------------------	--

User Para Hold Cur	A. 00 <u>24%</u>	Displays the positioning hold current.
-----------------------	---------------------	--

User Para Home Cur	A. 00 <u>50%</u>	Displays the home current limit value.
-----------------------	---------------------	--

User Para At ES, DB Efct	A. 00 <u>1</u>	Displays whether the dynamic brake is effective or not effective at emergency stop time. 1: Effective, 0: Not effective (RCS, E-Con)
-----------------------------	-------------------	---

- When soft limit is modified at the customer site, please set a value which extends 0.3mm outside of the effective area.

Example: When setting the effective area between 0mm~80mm

Soft limit + side: 80.3

Soft limit - side: -0.3

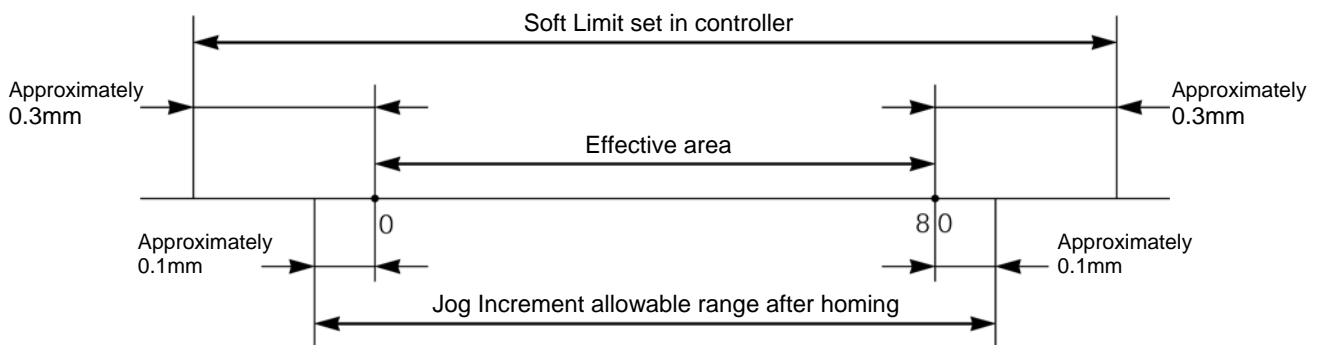

- After changing the homing direction, all saved position data will be cleared. As needed, please re-enter the data.
- Reversed homing direction may be done on the Rod Type Actuator.
- Homing direction setting is reversed on the Folded Type (SSR • SMR) Actuator (0: Correct, 1: Reversed).

**Caution:** After changing any parameter, be sure to execute restarting by turning on the power to the controller again or resetting the software. When resetting the software, press the ESC key after changing the parameter.

The following is displayed on the screen.

Software Reset	A. 00
* Reset?	Y → 1 N → 0

Press 1 with the numeric key and then press the Return key.

Software is reset and the parameter change becomes effective.

\* Regarding parameter, please refer to the RC Controller Operating Manual.

### 8-8 User Adjustment

Setting is made for enabling or disabling temporary stop (hold) input and servo ON input.  
The axis number setting is made for the integrated RC controller.

Mode Select * User Adjustment	A. 00	In the Mode Select Screen, using the ▲▼ Keys, select User Adjustment and then, press the Return Key.
----------------------------------	-------	--

Disable hold input:

User Adjustment Adjustment No.	A. 00 91	Input 91 into the adjustment number and then, press the Return Key. Afterwards, the controller must be turned OFF.
-----------------------------------	-------------	--

↑ Input 91

Enable hold input:

User Adjustment Adjustment No.	A. 00 90	Input 90 into the adjustment number and then, press the Return Key. Afterwards, the controller must be turned OFF.
-----------------------------------	-------------	--

↑ Input 90

Integrated RC Controller axis number setting:

User Adjustment Alloc. No.	A. 00 0	Input the axis number into the allocation number and then, press the Return Key.
-------------------------------	------------	--

↑ Input axis number



User Adjustment Adjustment No.	A. 00 2	Input 2 into the adjustment number and then, press the Return Key. If this procedure is done on a non-integrated controller, you will get error number 61. Afterwards, the controller must be turned OFF.
-----------------------------------	------------	---

↑ Input 2

Disable servo ON input (E-Con and RCS series only)

User Adjustment Adjustment No.	A. 00 93	Input 93 into the adjustment number and then, press the Return key. Afterwards, the controller must be turned OFF.
-----------------------------------	-------------	--

↑ Input 93

Enable servo ON input

User Adjustment Adjustment No.	A. 00 92	Input 92 into the adjustment number and then, press the Return key. Afterwards, the controller must be turned OFF.
-----------------------------------	-------------	--

↑ Input 92

**Caution:** Do not input any numeric values other than 2, 90 and 91 (92 and 93) into the adjustment number.

### 8-9 End

End is executed to save each setting or registration content of the Data Input Pendant.  
Before removing the Data Input Pendant from the RC controller, be sure to execute End.

Operation:

Press the BEGIN/END key for more than 2.5 seconds.

In a case that data input ends, and the Data Input Pendant needs to be removed

Op. Start / End  
\* End DU = Efct



Op. Start / End  
\* End DU = Non

Turn the RC Controller PORT Switch to OFF.  
Then, remove the connector.



In a case that you reconnect and wish to reopen

Op. Start / End  
\* Reconnection



Confirming Connection  
IAI RC DU V. 1.66



Select Axis  
\* Axis No. 00

(in a case of multiple axes connection)

Or

Mode Select A. 00  
\* Edit/Teach

(in a case of single axis connection)

**Caution:** When multiple axes are connected with a controller link cable, after recycling power of a controller that is not directly connected to the Data Input Pendant, please execute a reconnect.

## 9. Message Area

In the message screen, content during error and warning will be displayed.

Code No.	Error Label	Error Reset	Reference
000~07F	Controller Warning	Yes	Controller rejects command
080~0FF	Controller Error	Yes	Error inside the controller
100~1FF	DIP* Message	Yes	Input error, guide message, etc.
200~2FF	DIP* Movement Release	Yes	Movement continuation impossible
300~3FF	DIP Cold Start Error	No	DIP Power install or reconnect are necessary.

\* DIP in the table refers to the Data Input Pendant.

### 9-1 Warning Label Error (Code No. 000h – 07Fh)

Warning message is cleared by recovery procedure as follows:

Release operation:

1. First, confirm the cause of the warning and resolve the problem.
2. Press down BEGIN/END Key.

Warning is probably due to the following possibilities:

- RS485 communication abnormality
- Data Input Pendant operational mistake

a) RS 485 communication related abnormality

Indicates occurrence of any abnormality on the RS485 communication line.

Cause: Influence by foreign noise or connections are not properly installed.

The Data Input Pendant and RC controller execute packet communication (move instruction, data transfer, etc.) at all times. At this time, when data changes due to noise, the RC controller will determine that it is incorrect data and will reject the data.

Solution: (1) Confirm the above causes. In the case of frequent warning occurrences, please separately set the signal cable and power line.

(2) Be sure to use one unit to operate the RC controller.

See to it that the Data Input Pendant will not conflict with the PIO signal.



## **9-2 Data Input Pendant Message Level Error**

When you try to input an incorrect value by a Data Input Pendant operational mistake, a message level error occurs.

## **9-3 Controller Error**

Alarms detected from the controller side are displayed.

They are serious errors resulting from an abnormality with the servo control or electric system. Please carefully read the operating manual of the controller you use and take measures.

For details of the alarm codes and solutions as well, refer to the same operating manual.



## ***IAI America, Inc.***

Head Office: 2690 W. 237th Street, Torrance, CA 90505  
TEL (310) 891-6015 FAX (310) 891-0815

Chicago Office: 1261 Hamilton Parkway, Itasca, IL 60143  
TEL (630) 467-9900 FAX (630) 467-9912

Atlanta Office: 1220-E Kenneston Circle, Marietta, GA 30066  
TEL (678) 354-9470 FAX (678) 354-9471

Home page: [www.intelligentactuator.com](http://www.intelligentactuator.com)

## ***IAI Industrieroboter GmbH***

Ober der Röth 4, D-65824 Schwalbach am Taunus, Germany  
TEL 06196-88950 FAX 06196-889524